

REV	ECO	DESCRIPTION	DATE	BY	APP
B	3281	REDRAW, CHANGE WASHER	8/6/2009	GL	JK

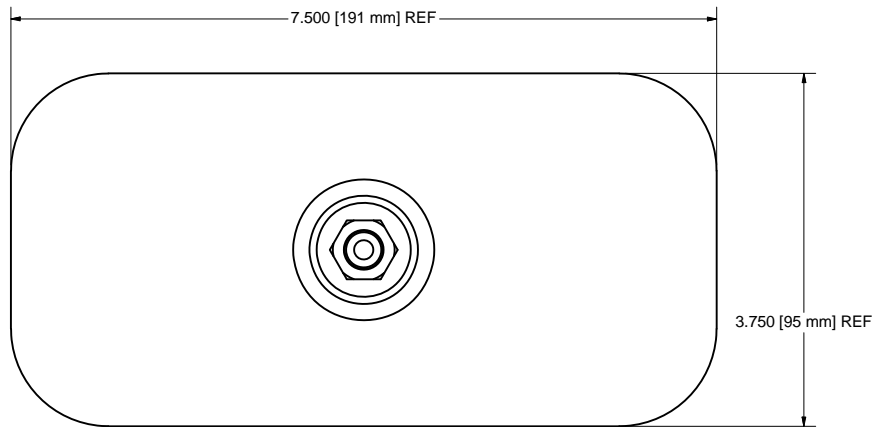
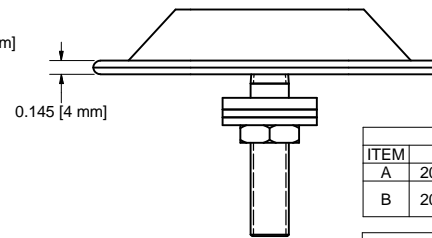
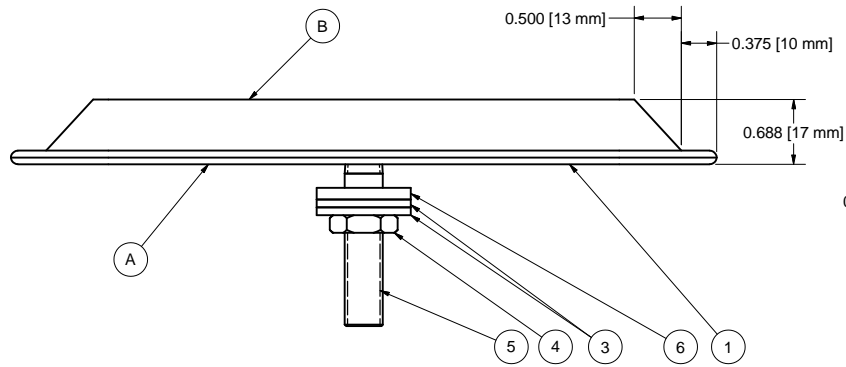
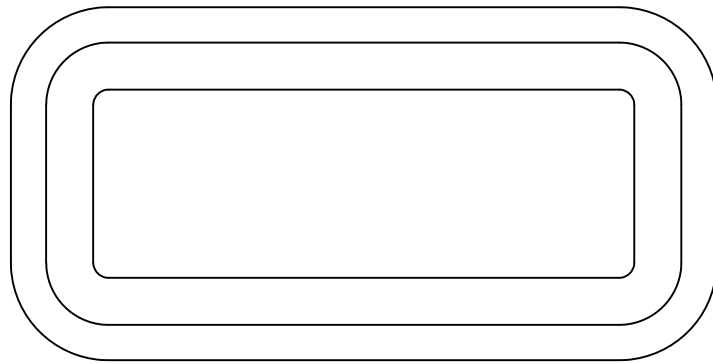

NOTES:

DIFFUSER EDGES MUST BE HELD BY BODY CRIMPING OPERATION TO PREVENT ANY DIFFUSER MOVEMENT IN AERATOR BODY.

SUB ASSEMBLY COMPONENTS: 20160058				
ITEM	PART	DWG	DESCRIPTION	QTY
A	20160041	B0160018	BODY BRACKET WELDMENT STN. STL	1
B	20160045	B0160023	FIBERGLASS STAINLESS STEEL DIFFUSER	1

SUB ASSEMBLY COMPONENTS: 20160057				
ITEM	PART	DWG	DESCRIPTION	QTY
A	20160041	B0160018	BODY BRACKET WELDMENT STN. STL	1
B	20160044	B0160023	COTTON STAINLESS STEEL DIFFUSER	1

PARTS LIST				
ITEM	PART#	DWG	DESCRIPTION	QTY
1	20160058 20160057		OPTIONAL: FS AERATOR - BODY & DIFFUSER - CLOSED - SST W/ FIBERGLASS CS AERATOR - BODY & DIFFUSER - CLOSED - SST W/COTTON	1
2	20160019	A0160027	Label AD Aerator A009RFBK	1
3	AD-9S		Stainless steel spacer washer	2
4	AD-16	A0160017	Nickel plated locknut.	1
5	AD-15	A0160016	Nickel plated tank nipple.	1
6	AD-10	A0160004	1/8" neoprene gasket.	1

MODEL AD-SSC: COTTON CLOTH DIFFUSER
MODEL AD-SSF: FIBERGLASS CLOTH DIFFUSER

HARDWARE PACKAGED UN-ASSEMBLED.

DRAWN RM	8/22/1983	 Conveyor Components Company 130 Seltzer Road Crosswell, Michigan, U.S.A., 48422
CHECKED JK	8/6/2009	
APPROVED CLO	8/24/1983	TITLE
PART		AERATOR FINAL ASSEMBLY: AD-SSC / AD-SSF
THIS PRINT IS PROPERTY OF CONVEYOR COMPONENTS CO., AND MAY NOT BE USED IN WHOLE OR PART WITHOUT WRITTEN PERMISSION.		Drawing is computer generated, and print might not be to scale
SIZE C	DWG NO C0160006.dwg	REV B
SCALE	SHEET 1 OF 1	